

Syntax SWP - Wall Mount Cabinet (IP-Outdoor)

The Syntax- SWP Weather Proof Wall Mount Cabinets Series- Provides the ideal solution in protection required for comms and data equipment for areas where dust and water are usually hazards. The additional 'Canopy Top' designed facilitate the mounting of ventilation fans for enhanced thermal properties. Special welded brackets are welded onto frameworks directly for fast and efficient wall mounting installation.

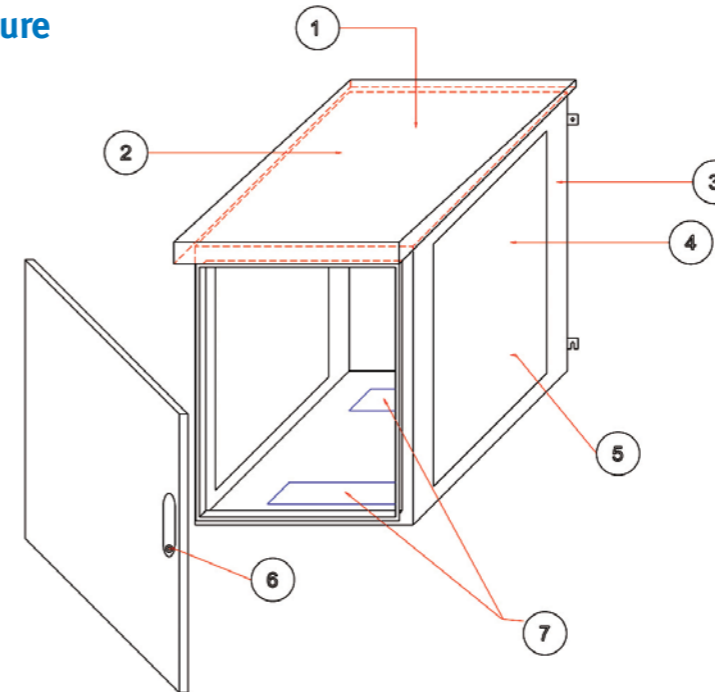

Main Structure



SWP Wall Mount

1. Top IP Canopy
2. 4 x Fan Units Underneath
3. 6 Way Power Distribution Unit (PDU)
4. 19" Panel Mount c/w Unit Indication
5. Removable Side Panel
6. Swing Handle Lock
7. Bottom Front & Rear Cable Entrance c/w Gland Plates

Main Dimension

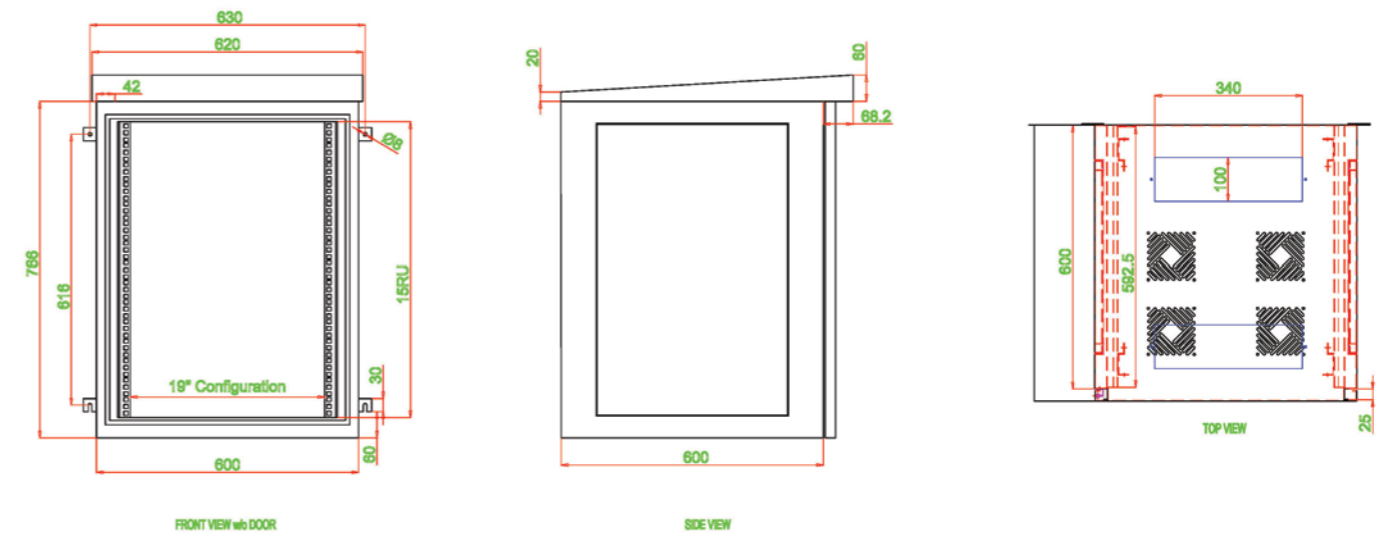

Standard

- Comply with ANSI/ EIA RS-310-D, DIN414197 part 1, IEC297-2, DIN41494 part 7, standard.

Features

- Reliable structure with welded Frameworks
- Special wall mounting welded brackets for easy installation.
- Additional Top Canopy for thermal control enhancement (Optional)
- Removable and lockable side panels (Optional)
- High Security locks ready (Optional)
- Up to IP55 protection
- Load rating at 60kg
- Bottom modular cable entrance
- Comprehensive range of sizes available upon request
- Various ventilation profiles and options available upon request
- Colour- Fully powder coated (RAL7035 Light Grey/RAL9004 Black)

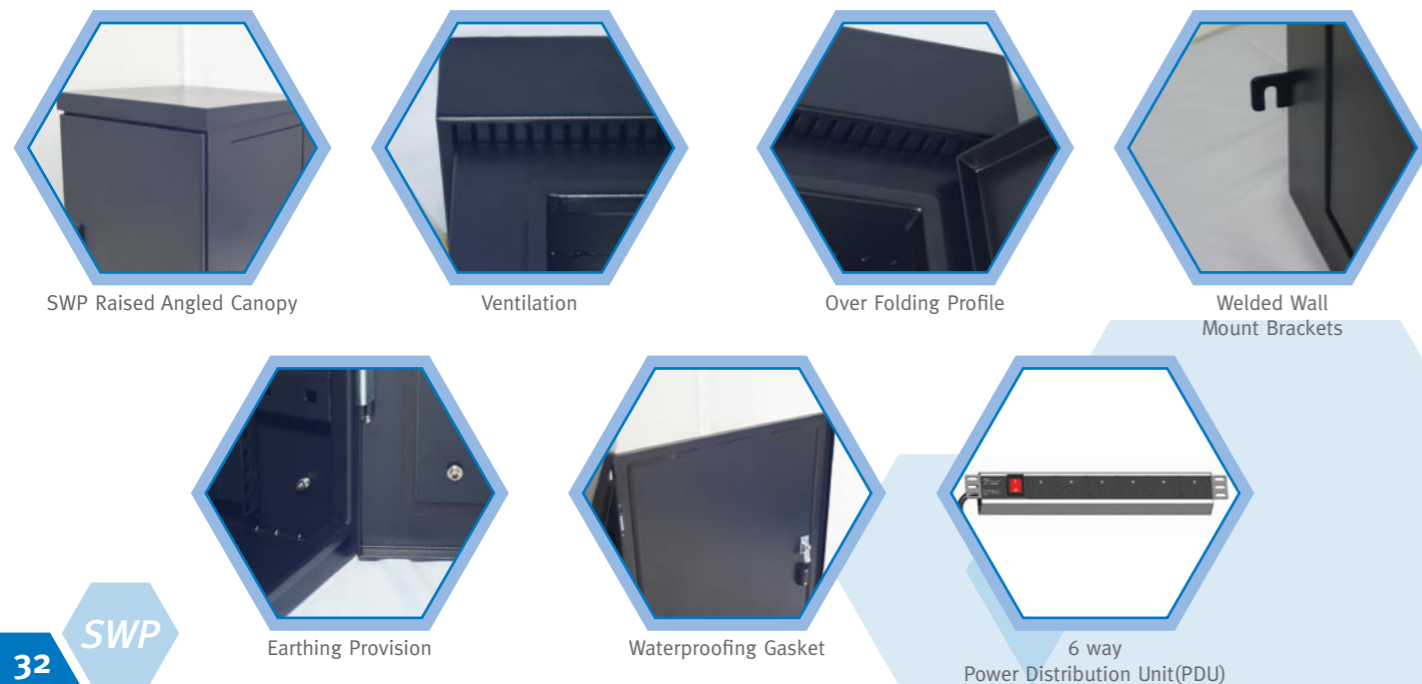

Ordering Information and Physical Sizing (*Height Includes Raised Angled Canopy ~ H60) (*Additional 50mm Width for Welded Wall Mount Brackets)

RU	W600 x D600	Height(mm)
6U	SWP6606	426
9U	SWP6609	560
12U	SWP6612	695
15U	SWP6615	826
22U	SWP6622	1140
27U	SWP6627	1360

(Please kindly check with our sales for further requirements)

Standard Scope of Supply

- Top Frame
- 2 x Bottom Cable Entrance with Gasket and Gland Plate
- 1 x Raised Angled Top Canopy c/w 4 x 4" Fan (Optional)
- 1 x Front Metal Door with Lock
- 2 x Removable Side Panels (Lock Optional)
- 1 set of Welded Wall Mount Brackets (Dia 8mm)
- 4 x Panel Mount with Unit Indication
- 1 x Power Distribution Unit (6 Way)
- 1 Packet of M6 Cage Nuts Assembly
- Finish with Epoxy Powder Coating